

# Universal Programmable Digital Timer Switch

A. M. Usman<sup>1</sup>, A. S. Rauf<sup>1</sup>, N. T. Surajudeen-Bakinde<sup>1</sup>, A. A. Oloyede<sup>2</sup>, O. S. Zakariyya<sup>1</sup>  
and A. O. Otuoze<sup>1</sup>

<sup>1</sup>Department of Electrical and Electronics, University of Ilorin, Kwara State, Nigeria

<sup>2</sup>Department of Telecommunication Science, University of Ilorin, Kwara State, Nigeria

*Email: usman.am@unilorin.edu.ng*

Received 12.01.2022, received in revised form 14.06.2022, accepted 17.06.2022

DOI: 10.47904/IJSKIT.12.1.2022.32-39

**Abstract-** Many electromechanical devices' operations are time-dependent. Different constituent parts are programmed to function on timestamp. In many home and industrial applications, timer switches form one of the major components. It is usually used for the operation of such devices. In this work, a simple but robust general-purpose universal programmable digital timer (UPDT) is proposed. The UPDT switch is a software-based timer with an interface that can be connected to a variety of devices to act as a switch for their operations. It is designed to perform a cyclic operation up to 100 times with a maximum switching time of 100 hours. The module presented in this work is capable of being used for the operation of a variety of devices such as utility load shedding devices, water pump control, automatic poultry feed dispenser, and automatic lawn watering system, among others.

**Keywords-** Automation, Microcontroller; Timer; Switch; Universal Programmable Digital Timer (UPDT).

## 1. INTRODUCTION

The concept of timing has various applications in different aspects of technological innovations and advancements. Its importance cannot be overemphasized and without it, many technological advancements would not be possible. Timing enables smooth synchronization of different integral parts of devices and applications' operation life cycle [1], [2]. Thus, timing is as important to the smooth operation of devices and applications as it is to humans. It must be accurate and precise as devices and applications work on timestamping without which failure is imminent [1]. Time sensitivity is the driving force behind many heterogeneous systems such as smart factories, autonomous driving, home automation, video calls, gaming, and web-browsing [1], [3]–[6].

The working of many electromechanical devices is time-dependent as different constituents' parts are usually programmed to function on time. Timer switches form one of the major components used in many homes and industrial applications for automatic operation. It uses a timing mechanism to control the operation of electromechanical devices, thus enhancing automation. It can be found in devices such as washing machines, home automation devices, utility load-shedding devices, poultry feed dispensers, heating, ventilation, and air conditioning

(HVAC) systems, automatic street light control, automobile, and aerospace among others [1], [3], [4], [7], [8].

In recent times, home and industrial devices are built to function automatically with the need for proper timing among the constituent parts within the operation period. Thus, accurate, precise, and reliable timing mechanisms are of great importance for the optimal operations of these systems. Besides automatic control of devices and applications, Timer switches can also contribute to power conservation by properly regulating power usage [3], [6], [7]. This has been one of the motivations behind the development of home automation control systems. Table 1 shows some of the past timer-related work.

Timer switches are either in hardware or software format or a combination of both. In hardware timers, the timing mechanism can be mechanical, electrical, or electromechanical and it is mainly used in the analogue switching operation. The software time, on the other hand, exists as computer code whose operation largely depends on the accuracy and precision of the clock generator. A timer switch can be assembled into the circuitry of a device or as a separate module to be coupled with the device.

Many electrical devices come with an inbuilt timer that is equipment specific in design. However, in this work, we are proposing a simple, general-purpose universal programmable digital timer (UPDT) switch. The module we are proposing is uniquely designed as a general-purpose digital timer that can be coupled to a variety of devices such as the utility load shedding device, pump control, automatic poultry dispenser, and automatic lawn watering system among others. The UPDT switch is a software-based timer with an electrical interface for external connection that can be coupled with a variety of electromechanical devices for switching operation. The UPDT switch implemented in this work can perform a cyclic operation up to 100 times with a maximum switching time of 100 hours. The work addresses the need for a general-purpose timer switch that can be implemented for automatic switching operation in electrical systems and subsystems for various industrial and home applications.

**Table 1:** A comparison table of some of the previous related work

Authors	Research objective	Research outcome
Seijo <i>et al</i> [1]	Investigation of time glitch transfer in a wireless channel.	A common based time outcome that allows smooth synchronization among all elements in a wireless network.
Garba <i>et al</i> [2]	Analyzing time-lag problem in digital clocks due to power loss.	An improved digital synchronizing clock that can transmit and receive information updates wirelessly. The module can be maintained remotely via a mobile application.
Oyedeki <i>et al</i> [3]	Design of Arduino-based timer system.	A simple inexpensive timer that controls the operation of an Electric cooker to enhance power conservation
Zakariyya <i>et al</i> [4]	Design of a Home automation system.	A bimodal home automation architecture using a Wi-Fi module.
Shrestha <i>et al</i> [5]	Addressing the problem of precise clock synchronization between participating nodes in a wireless network.	An improved precision time protocol (PTP) that supports precise time synchronization.
Kobayashi and Niitsu [9]	Design of gate-leakage-based timer.	A timer with a constant frequency that can function at a low voltage supply.

## 2. RELATED WORK

Several research works have been dedicated to addressing different time-related problems for various applications. The works are influenced by what is intended to be achieved with respect to timing. Examples of application of timing include designing timer switches for automatic control of devices [3], efficient global time-sharing end-to-end in a time-sensitive heterogeneous network [1], and precise timestamping between different modules within a network [9], efficient scheduling of software events [10]. In this section, some of these works are reviewed to give an insight into the diversity and ubiquitousness of timers in home and industrial applications.

Seijo *et al* [1] investigated the glitch of time transfer over a true-to-life wireless channel and proposed a time distribution structure containing three components: precision time protocol, a novel timestamping and an algorithm to execute the improved timestamps. The work addresses characteristic issues of delivering a common base time along with every element of a wireless network. ISO 5725-1:1994 standard definition of accuracy, trueness and precision were used as metrics to check the model performance. Their model was tested in MATLAB using IEEE 802.11n Standard and the outcome showed that the systems can reach sub-nanosecond time transfer accuracy under non-line-of-sight and time-variant conditions. However, the performance is hugely subjected to the signal-to-noise ratio (SNR) and the channel variation rate. Similarly, an improved precision time protocol (PTP) was proposed in [5] to support precise clock synchronization among nodes within an industrial wireless network deployed for critical control and automation applications. The problems of precise

clock synchronization between the clocks of participating nodes and accurate timestamp message decoding between nodes in an industrial communication network were critically analyzed by the authors. Furthermore, they proposed an enhanced PTP for high-performance wireless communication for time-sensitive networking with a simple but strong symbol timing synchronization for the accurate timestamp message decoding during the enhanced PTP execution. Their simulation results reportedly showed improved performance in contrast to the conventional PTP.

Kobayashi and Niitsu [9] developed a gate-leakage-based timer that makes use of an amplifier-less replica-bias switching methodology that produces a constant frequency that can function at a low supply voltage. The circuit of the timer adopts a framework that discharges a pre-charged capacitor through a resistive element with a low-leakage switch to guarantee a constant oscillation frequency. The switching technique in the timer operates by tracking the discharging terminal of the capacitor and biasing the reference voltage of the switch unit. The test chip of the timer was assembled using the 55-nm deeply depleted channel (DDC) CMOS technology, which is said to have a strong body coefficient and occupies an active circuit area of 0.0022 mm<sup>2</sup>. The authors reported that when biasing is used, the model can achieve an energy-per-cycle value of 25 pJ/cycle at a supply voltage of 350mV. It was also reported that the timer showed an average temperature sensitivity of 810 ppm/°C for four samples.

Oyedeki *et al* [3] developed an Arduino microcontroller-based electric cooker timer system. The system allows users to enter a time range for the operation of the cooker and it turns OFF automatically after the set time has elapsed. A buzzer

is incorporated into the system to give an audio notification at a preset time to notify the users of the progress of an operation. The timer switch serves as its power switch as well as a source of safety measures. A keypad is incorporated to input the time as the users will deem fit, and of course subject to the limit set during the design. The module can increase safety and reduce hazards associated with the use of an electric cooker, besides reducing power wastage.

Not with standing the number of previous works done on timer switch, the continuous quest for automation in the operation of devices give room for the advancement of newer timer switches that will be more efficient in terms of cost and operation. Mainly, in this work, a simple but robust general-purpose UPDT switch is being proposed with an advantage to be used in different areas of applications such as utility load shedding devices, water pump control, and automatic poultry feed dispenser, automatic

lawn watering system, among others. The proposed switch also presents an improved timing precision, elongated timing range (100 hours), universal adaptability, and user interactive interface.

### 3. DESIGN AND IMPLEMENTATION

The UPDT switch proposed was conceptualized, designed, and executed using both hardware and software approaches. The block diagram of the proposed UPDT switch is shown in Figure 1. The module comprises the following: the power supply unit (PSU), the input unit, the control unit, the output unit, and the display unit. The details of the design and implementation of each of the units are discussed in this section. The module comprised both the hardware circuit design and software programming using an embedded system and the coding was done in C-programming language.

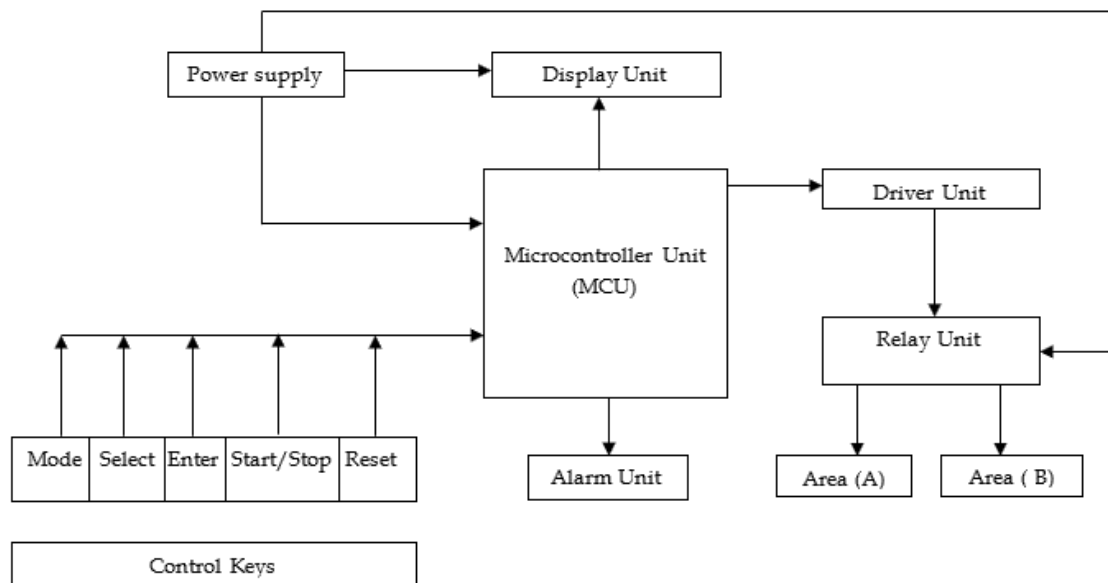

Figure 1. The block diagram of the proposed UPDT switch

### 3.1 Hardware Components

#### 3.1.1 Power Supply Unit (PSU)

This unit provides the power to all other constituent components of the module. The PSU transforms the 240 V Alternating Current (AC) supply from the mains to a regulated 15 V. It consists of a stepdown transformer, diodes, filtering capacitor, and voltage regulator. A 240/15 V, 50 Hz step-down transformer with a 500 mA current rating is used in this work. The choice of this transformer is arrived at in order to reduce the mains supply voltage to a value that will not exceed the peak inverse voltage of the diode

rectifier. The peak voltage  $V_m$  of the secondary transformer,  $V_m$  is given as shown in Eq. (1):

$$V_m = \sqrt{2} \times V_{rms} = 21.21 V \quad (1)$$

where  $V_{rms}$  is the root mean square voltage of the transformer secondary voltage.

The regulated 15 V AC stepped down from the 240 V mains is passed through the bridge rectifier to get the equivalent Direct Current (DC) voltage. The IN4001 diode with a 50 V peak inverse voltage (PIV) was used in this work, after the calculations in Eq. (2) for the full-wave rectification:

$$PIV = 2 \times V_m = 2 \times 21.21 V = 42.42 V \quad (2)$$

However, the DC voltage generated had some ripples. The filtering capacitor is used to filter the ripples. When using a full-wave bridge rectifier, the ripple factor ( $\gamma$ ), is about 6% from the datasheet, so

$$\text{Ripple factor}(\gamma) = \frac{I_{dc}}{4\sqrt{3} \times f \times C \times V_{pp}} \quad (3)$$

where  $V_{pp}$  is the peak voltage for a bridge rectifier, 19.81,  $I_{dc}$  is the transformer current rating, 500 mA, and  $f$  is the frequency of the transformer, 50 Hz.

From Eq. (3), we have:

$$C = \frac{I_{dc}}{4\sqrt{3} \times f \times \gamma \times V_{pp}} \quad (4)$$

$C = 1214 \mu\text{F}$ , therefore a 1500  $\mu\text{F}$  capacitor and a 25

V  $V_{pp}$  were the appropriate value chosen.

The filtered voltage is passed through LM7812 and LM7805 and LM7812 [11], [12] voltage regulators to obtain the 5 V DC needed to power the microcontroller unit and 12 V DC needed to power the relay circuit respectively. An optional 12V battery can be incorporated to serve as backup. The PSU circuit is shown in Figure 2, while Figure 3 shows the PSU with a 12 V DC battery option.

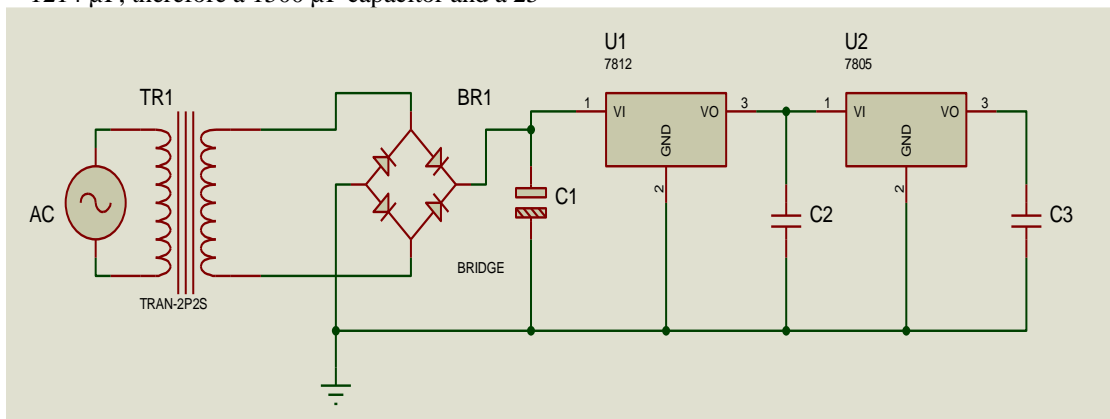

Figure 2: The PSU

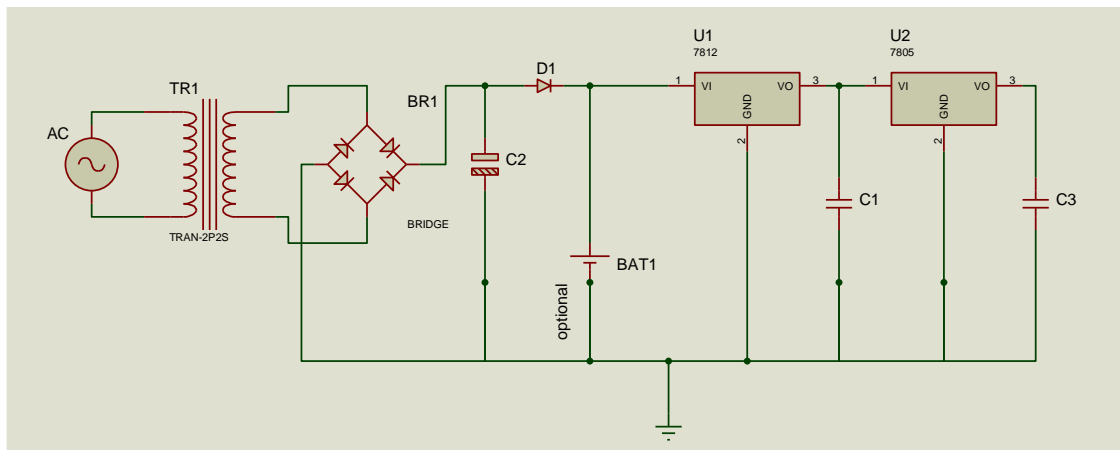

Figure 3: The PSU with a 12 V DC battery option

### 3.1.2 Input Unit

This unit allows users to enter instructions into the module. Instructions such as settings of hours of operation (ON and OFF time), and the number of cycles of operation. As can be seen from Figure 1, the input unit is made up of a keypad sub-circuit, a 5-tact keys (Mode, Select, Enter, Start/Stop, and Reset). The Mode button allows the user to navigate through various menu options such as ON/OFF time setup,

cyclic option etc., these options are displayed on the LCD. This button also serves as a digit incremental (+) for setting ON/OFF time. The time is set in HH:MM format, which gives the minimum value of timing to be 1 minute. The Select button allows the user to choose the currently displayed menu option on the LCD as well as select between the hour and minute digits. The selected digit is incremented by 1 when pressed. While the enter

button is used to send the final instruction. The cyclic option is also set using this button. The Start/Stop button is used to start and stop the timer after all inputs have been set by the user. If the timer is in ON state, it can be stopped during operation by pressing this button. Finally, the Reset button is used to interrupt and clear the memory of the timer for new instructions to be passed again.

**3.1.3 Control Unit**

The control unit coordinates the operations of the module. It can be described as the ‘brain’ of the module. The PIC16F628A microcontroller, a low-power, high-performance, CMOS FLASH-based, 8-bit [13] is used to achieve this unit. The microcontroller was programmed with code (hex file) generated from its corresponding embedded C-language code written in MikroC PRO for PIC, a powerful-rich tool for PIC microcontrollers. MikroC PRO for PIC is a robust tool that allows the development and deployment of complex applications and its features are explained in detail in [14].

**3.1.4 Output and Display Units**

The output signal obtained from the control unit is used as the control signal to determine the state of the relay. The relay interfaces between the microcontroller unit and the targeted system are to be timed.

The display unit is used to visually display the activities of the module. A 16x2 alphanumeric liquid crystal display (LCD) is used. The detailed working principle of LCD is explained in [15]. The LCD is configured to display information about the module operation with different partitions. Information such as the active load, time left, and the number of cycles completed is displayed.

**3.2 Software Components**

The microcontroller unit forms the major component of the software section of the module. The data and instructions of operation are programmed into the microcontroller using embedded C-language. The virtual circuit simulation is done using Proteus ISIS Design Suite, a general electronic software tools use for designing and simulating electronic circuits [16]. The simulated circuit diagram is shown in Figure 4.

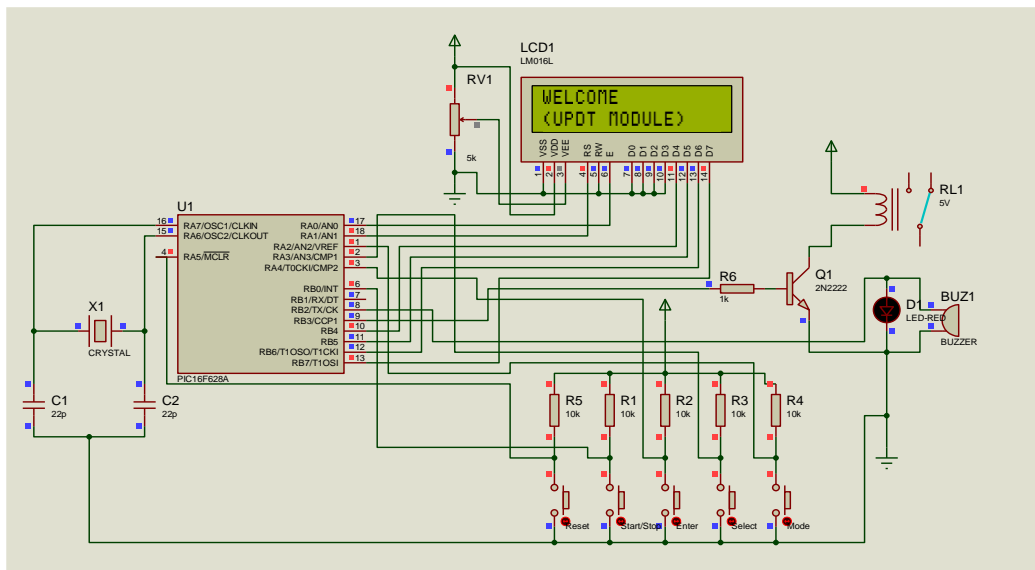

**Figure 4:** Simulated Circuit diagram of the module

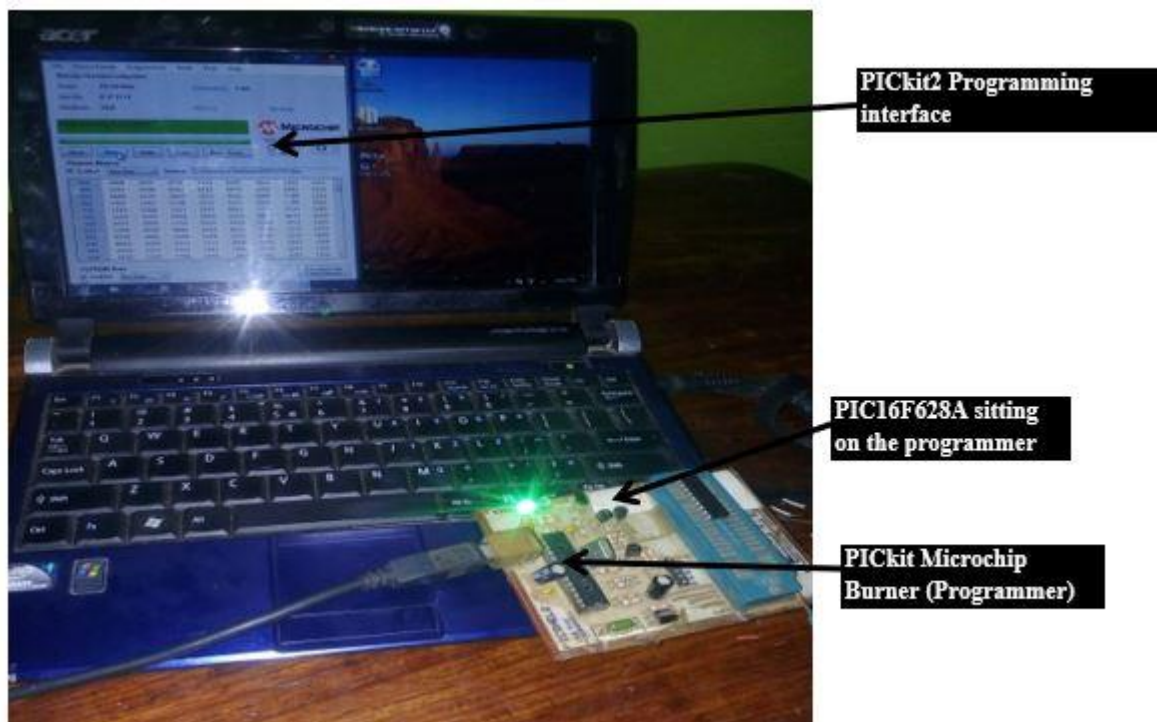

Fig. 5: Software Implementation

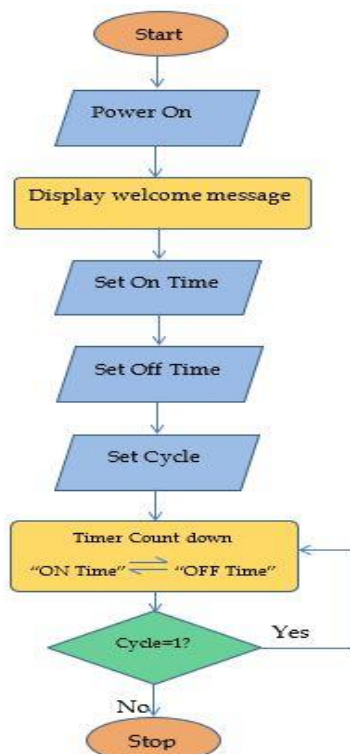

Fig. 6: Flowchart of UPDT Switch

### 3.3 Implementation

The implementation stage involved assembling the different units and ensuring that each module work as per design. The circuit design was

done using virtual simulation, the Proteus ISIS Design Suite. The ‘Hex’ code (source code) for the microcontroller was generated from mikroC IDE. The code was then copied on the PIC16F628A microcontroller’s memory through in-circuit-serial programming (ICSP). Virtual testing was done, and necessary corrections were made as applicable. Figure 5 shows the software implementation pictures. The physical implementation was then first implemented on a breadboard, to ascertain the workability of the design. The design layout was strictly followed during this stage. Following a satisfactory output from the breadboard connection, a final implementation was done on the Vero board by permanently soldering all the components according to the circuit design layout. The soldering process was done following standard soldering principles as stated in [17]. This is to guarantee that there is a good harmonious electrical and mechanical connectivity among the components and units of the UPDT switch. The flowchart of the working of the module is shown in Figure 6.

### 4 RESULT AND DISCUSSION

The developed UPDT switch was tested on a load-shedding device to serve as the switch to shed power supply between separate communities. Two light bulbs are used to represent each of the two communities. Each of the bulbs was connected to the normally open (No) and normally closed (Nc) terminals of the relay. When the 240V AC mains is supplied, the PSU output a regulated 5V DC as

explained earlier, to power other units of the module. The LCD turns ON displaying “WELCOME (UPDT MODULE)” with 5 seconds delay. Then, there is a display of “00:00” corresponding to “00hour:00minute”. The keypad is used to input instructions into the module. Table 2 shows the keypad combinations for passing instruction into the module as well as the performance evaluation. The module was able to carry out the automatic switching operation between the test loads (the two bulbs) according to the time set for each load by the user. At the expiration of the set time, the user is alerted through the bleeping of the buzzer and glowing LED.

In this case, where the module is used as a switch to a load-shedding device, each bulb represents the load demand of the corresponding area- AREA A and AREA B. It is assumed that Area A needs more hours of power supply than Area B. Therefore, the module is set to give more hours to Area A than Area B. For the test in view, 1 minute is used to represent 8 hours of power supply. So, Area

A was set to 2 minutes (indicating 16 hours of power supply) and Area B is to 1 minute (indicating 8 hours of power supply). The operation of the module was synchronized with the local time. The module was activated at 4:00 p.m. This implied that Area A was connected from 4:00 p.m. till 8:00 a.m. (the next day) when the buzzer and LED will bleep and glow respectively, indicating the expiration of time and switching operation to disconnect Area A, while Area B will be connected automatically from 8:00 a.m. till 4:00 p.m. This “auto-switch” operation continues repeatedly till the number of cycles completed reaches 100. This gives a hundred-day of uninterrupted automatic switching operation. This is of one the major contributions of this work. Another contribution is that the module can be set to a maximum connecting time of 100 hours for each area. In such instance, with the cyclic operation being activated, the module can perform an "auto-switch" operation for 20,000 hours. This is corresponding to 833 days and 6 hours before a reset will be needed. Table 3 shows the result obtained from the test carried out.

**Table 2:** Summary of Performance Evaluation of the Module

S/N	Button	Function	Buzzer	LED	LCD	Comment
1	Power switch ON	Connect the module to mains	OFF	OFF	WELCOME (UPDT MODULE)	LCD displays for 5secs
2	Mode	Navigate through menu options and increment the selected digit	OFF	OFF	AREA A TIME = 00:00	The 1 <sup>st</sup> area is selected here
3	Select	Select between hour and minute digits	OFF	OFF	AREA A TIME= 00:0 <u>2</u>	The 1 <sup>st</sup> time is set here
4	Enter	Finalizes the setting	OFF	OFF	AREA A TIME= 00:02	The time is set to 2minutes
5	Mode	Navigate through menu options and increment the selected digit	OFF	OFF	AREA B TIME = 00:00	The 2 <sup>nd</sup> area is selected
6	Select	Select between hour and minute digits	OFF	OFF	AREA B TIME= 00:0 <u>1</u>	The 2 <sup>nd</sup> time is set here
7	Enter	Finalizes the setting	OFF	OFF	AREA B TIME= 00:01	Time is set to 1minute
8	Mode	Navigate through menu options and increment the selected digit	OFF	OFF	>TIMER CYCLE Y / N = <u>0</u>	Timer cycle is selected
9	Select	Select between hour and minute digits	OFF	OFF	>TIMER CYCLE Y / N = <u>1</u>	Cyclic mode is set to ON
10	Enter	Finalizes the setting	OFF	OFF	>TIMER CYCLE Y / N = 1	Cyclic mode is activated
11	Start / Stop	Activates the system	ON	ON	AREA A TIME= 00:02	LED & Buzzer ON for 1sec., 1 <sup>st</sup> bulb glows and time starts the countdown
12	Reset	Interrupts the operation and restarts the module	OFF	OFF	DEFAULT MESSAGE	Starts over

**Table 3:** Summary of Results obtained from the test carried out

Step	LCD status	Module operation
1	WELCOME (UPDT MODULE)	Starting up
2	AREA A >00 TIME = 00:02	1 <sup>st</sup> bulb is connected to mains for 2 minutes
3		Buzzer beeps and LED glows for 1 second
4	AREA B >00 TIME = 00:01	2 <sup>nd</sup> bulb is connected to mains for 1 minute
5		Buzzer beeps and LED glows for 1 second
6	Step (2-5) is repeated	

## 5 CONCLUSION

A simple but robust general-purpose UPDT switch has been designed and implemented in this work. The UPDT switch implemented in this work can perform a cyclic operation up to 100 times and a maximum switching time of 100 hours per cycle. The work addresses the need for a general-purpose timer switch that can be implemented for automatic switching operation in electrical systems and subsystems for various industrial and home applications. It can be used as a switch for the operation of devices such as utility load shedding devices, pump control, automatic poultry feed dispenser, and automatic lawn watering system, among others.

**Acknowledgement:** The authors acknowledge the University of Ilorin, Ilorin, Nigeria for the support in carrying out this research work.

## REFERENCES

- [1] O. Seijo, J. A. Lopez-Fernandez, H. P. Bernhard, and I. Val, "Enhanced Timestamping Method for Subnanosecond Time Synchronization in IEEE 802.11 over WLAN Standard Conditions," *IEEE Transactions on Industrial Informatics*, vol. 16, no. 9, pp. 5792–5805, Sep. 2020, doi: 10.1109/TII.2019.2959200.
- [2] S. Garba, B. Yahaya, B. O. Sadiq, D. A. Udekwe, and Z. M. Abubakar, "Implementation of Timing and Synchronization in Digital Clocks: A Wireless Communication Design," 2019 2nd International Conference of the IEEE Nigeria Computer Chapter (NigeriaComputConf), pp. 1–4.
- [3] A. O. Oyediji, A. P. Oni, F. Onaifo, and P. O. Alao, "Development of an Arduino Based Electric Cooker Timer System," *JITCE (Journal of Information Technology and Computer Engineering)*, vol. 4, no. 01, pp. 28–31, 2020, doi: 10.25077/jitce.4.01.28-31.2020.
- [4] O. S. Zakariyya, A. F. Salami, O. O. Alabi, and A. M. Usman, "Design of a Bimodal Home Automation System using ESP8266 and ATMEGA328 Microcontroller," *Computer Engineering and Applications*, vol. 6, no. 3, 2017, Accessed: May 20, 2021. [Online]. Available: <https://uilspace.unilorin.edu.ng/handle/20.500.12484/4631>.
- [5] D. Shrestha, Z. Pang, and D. Dzung, "Precise clock synchronization in high performance wireless communication for time sensitive networking," *IEEE Access*, vol. 6, pp. 8944–8953, Feb. 2018, doi: 10.1109/ACCESS.2018.2805378.
- [6] A. M. Usman, O. Ibrahim, Y. S. Muhammed, A. O. Otuoze, O. S. Zakariyya, and M. A. Afolayan, "Design and Construction of an Automatic Home and Office Power Control System," *FUOYE Journal of Engineering and Technology*, vol. 6, no. 2, Jun. 2021, doi: 10.46792/FUOYEJET.V6I2.597.
- [7] H. A. Attia and B. N. Getu, "Authorized timer for reduction of electricity consumption and energy saving in classrooms," *International Journal of Applied Engineering Research*, vol. 11, no. 15, pp. 8436–8441, 2016.
- [8] A. M. Usman, Y. A. Adediran, A. O. Otuoze, O. O. Mohammed, and O. S. Zakariyya, "Replacement Model for Street Lighting Systems," *Nigerian Journal of Technology*, vol. 40, no. 1, pp. 49–55, Mar. 2021, doi: 10.4314/njt.v40i1.8.
- [9] A. Kobayashi and K. Niitsu, "Low-Voltage Gate-Leakage-Based Timer Using an Amplifier-Less Replica-Bias Switching Technique in 55-nm DDC CMOS," *IEEE Open Journal of Circuits and Systems*, vol. 1, pp. 107–114, Jul. 2020, doi: 10.1109/ojcas.2020.3007393.
- [10] M. Aron and P. Druschel, "Soft timers: Efficient microsecond software timer support for network processing," *ACM Transactions on Computer Systems*, vol. 18, no. 3, pp. 197–228, Aug. 2000, doi: 10.1145/354871.354872.
- [11] Shawn, "LM7805 Voltage Regulator: Features, Comparisons and more - Latest open tech from seeed studio," 2019. <https://www.seeedstudio.com/blog/2019/10/30/lm7805-voltage-regulator-features-comparisons-lm317-and-more/> (accessed Dec. 31, 2020).
- [12] P. Ian, "7800 Voltage Regulators: 7805, 7812, etc » Electronics Notes." [https://www.electronics-notes.com/articles/analogue\\_circuits/power-supply-electronics/7805-7812-voltage-regulator.php](https://www.electronics-notes.com/articles/analogue_circuits/power-supply-electronics/7805-7812-voltage-regulator.php) (accessed Jun. 16, 2021).
- [13] M. R. Rezoug and A. Krama, "Control device for automatic orientation of a solar panel based on a microcontroller (PIC16f628a)," in *AIP Conference Proceedings*, 2016, vol. 1758, no. 1, p. 30046.
- [14] MikroC PRO for PIC, "Introduction to mikroC PRO for PIC." [https://download.mikroe.com/documents/compilers/mikroc/pic/help/introduction\\_to\\_mikroc\\_pro\\_for\\_pic.htm](https://download.mikroe.com/documents/compilers/mikroc/pic/help/introduction_to_mikroc_pro_for_pic.htm) (accessed Jun. 01, 2021).
- [15] A. Aidan, "LCD Screens and the Arduino Uno - Tutorial Australia." <https://core-electronics.com.au/tutorials/use-lcd-arduino-uno.html> (accessed Jun. 04, 2021).
- [16] S. Syahminan and C. W. Hidayat, "Development of digital engineering learning with proteus software media and emulators department of informatics engineering Kanjuruhan University," in *Journal of Physics: Conference Series*, Apr. 2021, vol. 1869, no. 1, p. 12076, DOI: 10.1088/1742-6596/1869/1/012076.
- [17] K. L. Chia, B. L. Choo, S. J. Lee, C. T. S. Luang, M. S. Tan, and T. Truman, "Robotic soldering of lead free alloys," in 2018 Pan Pacific Microelectronics Symposium (Pan Pacific), 2018, pp. 1–10.